

TianLi 全国服务热线
400-1122-958
15988580888

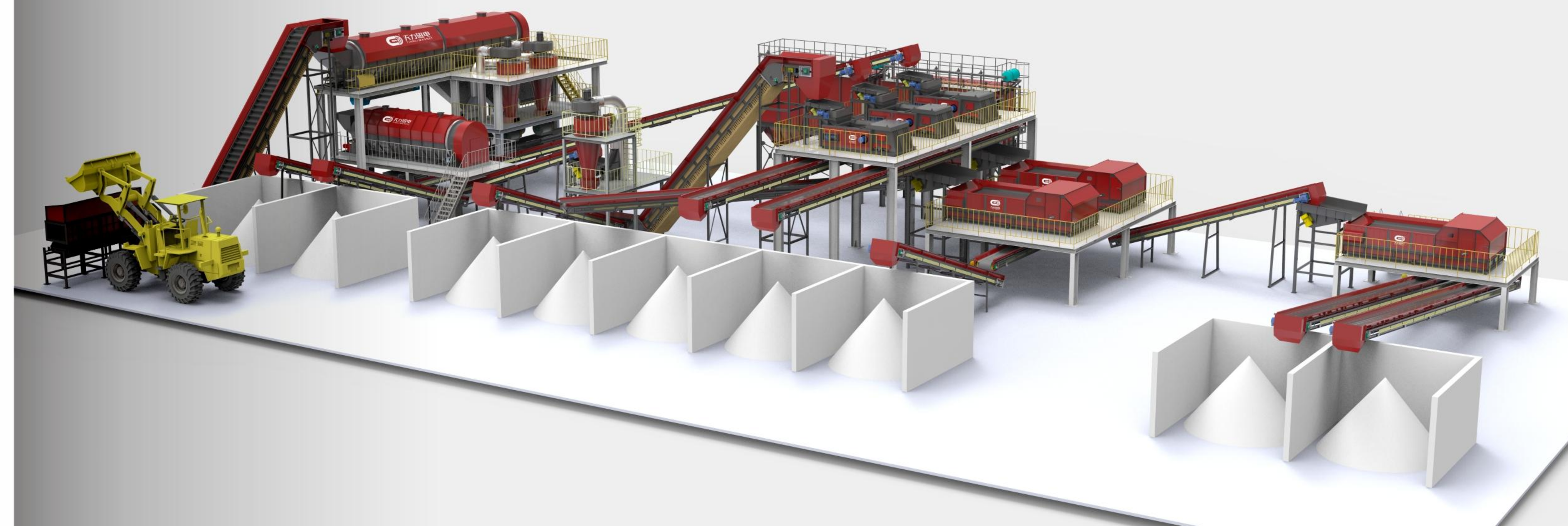

最具吸引力的磁电、
固废分选装备供应商!



天力磁电 · 废钢行业

TIANLI MAGNET STEEL SCRAP SEPARATOR



浙江天力磁电科技有限公司
ZHEJIANG TIANLI MAGNET TECHNOLOGY CO., LTD.

地址 (Add): 浙江省东阳市书院路11号
NO.11 SHUYUAN ROAD, DONGYANG CITY, ZHEJIANG PRO, CHINA
电话 (Tel): 0579-86816586 400-1122-958
传真 (Fax): 0579-86816587 0579-86817958
邮箱 (Email): tl@tianlimagnet.com
网址 (Web): www.dytldcsb.com www.tlmtech.cn



关注公众号
了解更多资讯

浙江天力磁电科技有限公司
ZHEJIANG TIANLI MAGNET TECHNOLOGY CO., LTD.

TABLE OF CONTENTS 目录

- 01** 废钢尾料预选分选线
Auto Shredder Residual Pre-Sorting Solution
- 03** 有色金属分选线
Metal Sorting System Solution
- 04** 不锈钢分选线
Stainless Steel Sorting System Solution
- 05** TLFXP 偏心涡电流分选机
TLFXP Eccentric Eddy Current Separator
- 07** TLFX 同心涡电流分选机
TLFX Concentric Eddy Current Separator
- 08** TLZ 空气分选设备
TLZ Air Separation
- 09** TLCG 电磁传感式分选机
TLCG Metal Sorter

- 11** TLGTS 滚筒筛
TLGTS Drum Screen
- 11** TLCZ 弛张筛
TLCZ Vibratory Screens
- 12** TLRL 燃料棒压块机
TLRL Fuel Rod Briquetting Machine
- 13** 废钢厂塑料清洗回收线
Introduction Of Plastic Cleaning And Recycling Line In Scrap Steel Aactory
- 15** 废钢分选配套产品
Scrap Sorting Accessory Products
- 19** 客户案例现场
Scene Of The Case
- 28** 售后服务承诺
Service Commitment

公司集科研开发、工艺设计、安装服务于一体，是磁选、除铁、起重、涡电流分选、智能传感分选、智能分拣机器人及各种固废分选设备的专业化制造公司，公司与国内多所高校和科研单位密切合作，先后开发出磁选、除铁、起重、涡电流分选、智能传感分选、智能分拣机器人、移动分选、固废分选等几十种产品几百个规格，公司拥有多项发明专利，几十项实用新型专利。

COMPANY PROFILE



公司简介

浙江天力磁电科技有限公司是景森控股的全资子公司，国家高新技术企业，成立于2006年，位于素有“中国磁都”“东方好莱坞”之称的浙江省东阳市，交通便利，距义乌机场仅20公里。

公司产品广泛应用于矿山、建材、煤炭、砖瓦、冶金、化工、造纸、橡胶、玻璃、食品、环保等行业及生活垃圾、陈腐垃圾、废旧电子电器、建筑装修垃圾、大件垃圾、废钢尾料、垃圾发电厂焚烧炉渣处理等城市矿产行业。

公司拥有自营进出口权，产品遍布全国各地并出口三十多个国家的地区，凭借良好的企业资质、先进的生产技术、过硬的产品质量、合理的价格、完善的售后服务，与广大客户真诚合作、开拓进取、共图发展，向世界一流的企业迈进，公司全体员工热情欢迎国内外新老客户光临指导。

Zhejiang Tianli Magnet Technology co., Ltd, focus on the Magnetic&sorting, eddy current separation, sensor separation technology application, provides material recycling and processing solutions for industry such as recycling, mining, electricity and construction, etc.

Especially in recycling industry, by the innovative product like ESC machine, sensing metal separator, drum magnet, etc. and optimized solutions, we can guarantee metals recovery reach to 95-98% when they are employed in PET plastic scrap steel, waste refrigerator, sawdust, living garbage, paper pulp and other processing line and bring big profits to clients.

Tianli company attaches great importance to brand promotion and participates in conferences and exhibitions of various industries at home and abroad every year, including Shanghai, Guangzhou, Germany, America, Australia, Singapore, South Korea, etc. We always keep close communication with customers, constantly absorb and introduce foreign new ideas and technologies, and constantly develop and improve our products.

Tianli company has developed rapidly and is a direct supplier of magnetic separation, eddy current separator, induction separator and other equipment to many engineering companies, contractors and technical consulting companies at home and abroad. We look forward to further cooperation with you!

废钢尾料预分选系统方案 AUTO SHREDDER RESIDUAL PRE-SORTING SOLUTION

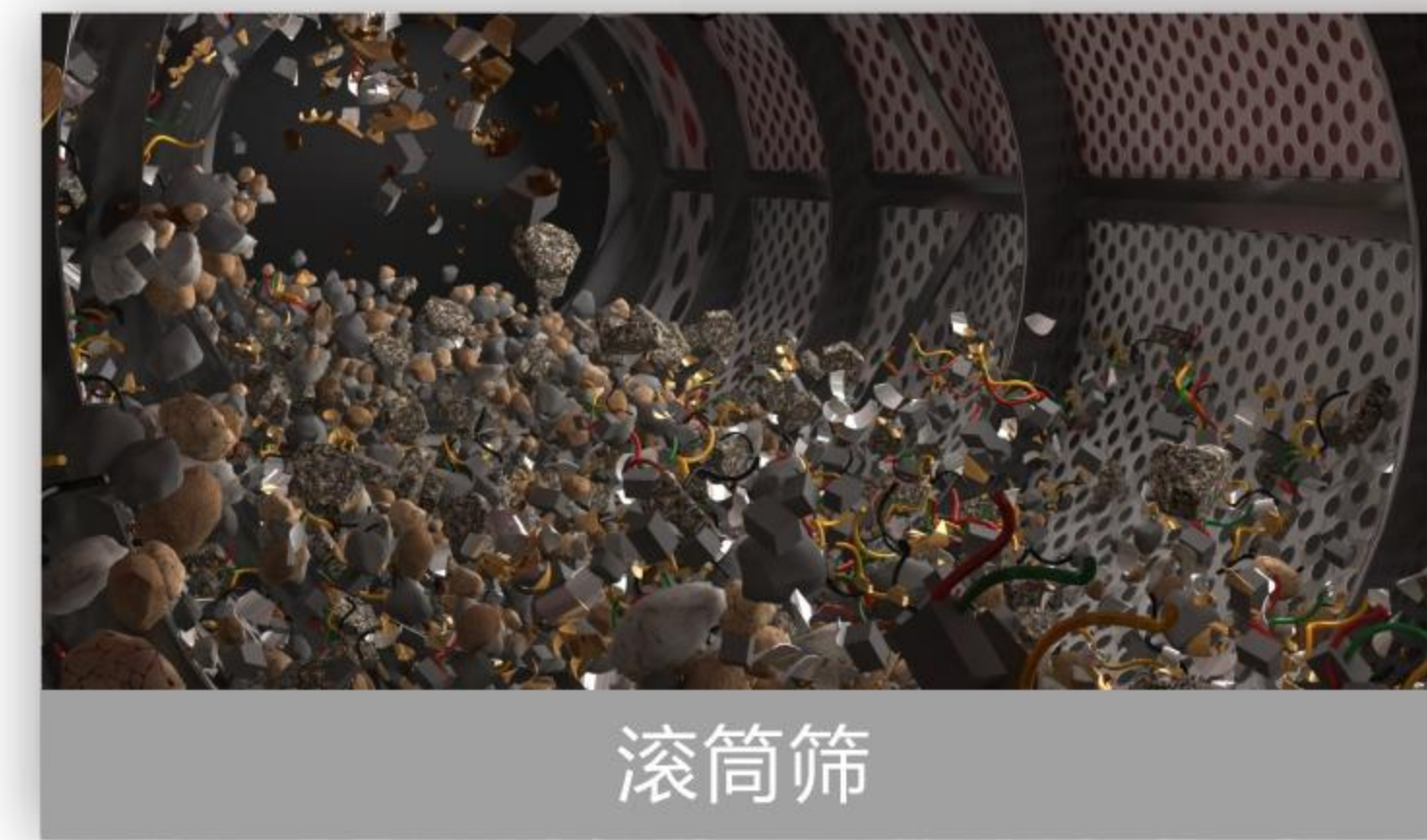

滚筒筛

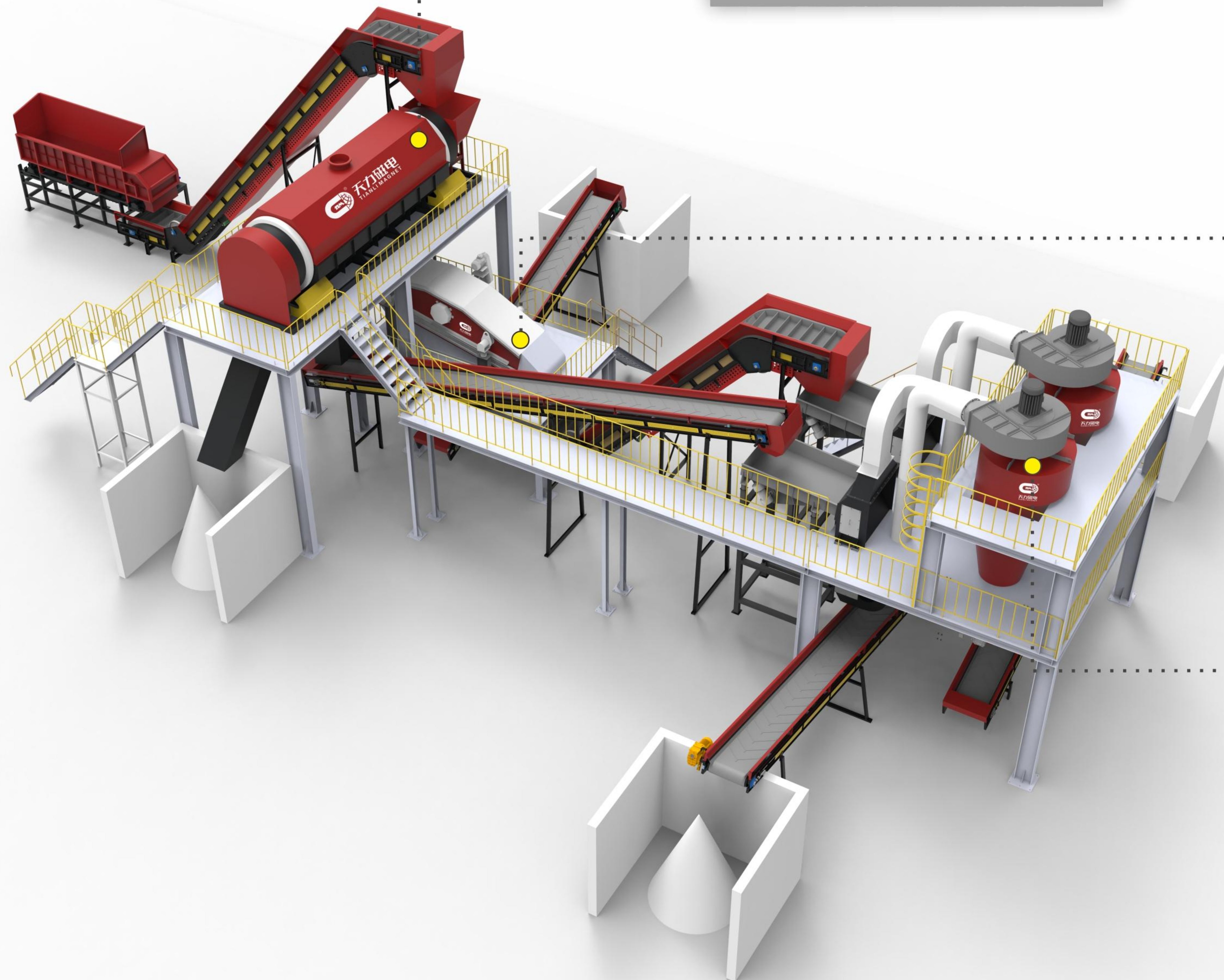

方案目的 PROGRAM OBJECTIVES

针对目前物料比较潮湿，同时需要对小颗粒进行筛分，我们采用了滚筒筛和弛张筛的组合模式，先将大颗粒进行分离，然后，小颗粒进入到弛张筛，利用弛张筛的筛分效率高及有效的筛网防堵特性，将小颗粒进行有效的筛分；筛分完之后的物料再进入到空气分选系统，分离出轻物质，分离出来的物料再进入到金属分选系统，可有效的提高金属分选系统的分选效率，该预分选系统有离线分选和在线分选两种选择。



弛张筛

Based on the current material is damper, at the same time need to screening of small particles, we adopt the combination pattern of roller screen and relaxation sieve, large particle separation first, then the small particles into the relaxation sieve, using the relaxation sieve high screening efficiency, screen mesh and effective prevent features, will be small particles for effective screening, screening after the material again into the air separation system, separation of the light material, the separated material into metal separation system, which can effectively improve the separation efficiency of metal separation system, the preassigned have offline and online sorting separation system of two options.

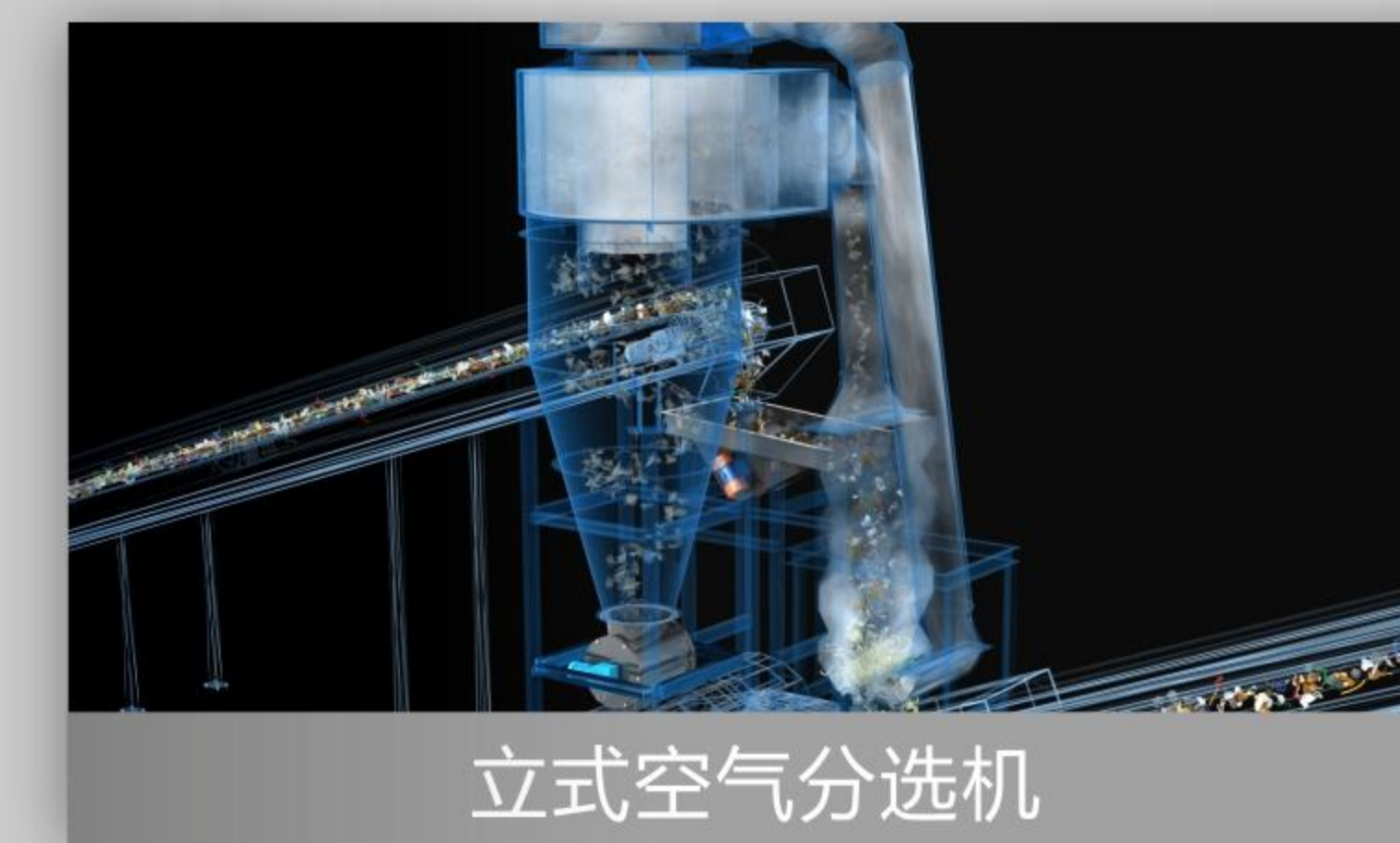

立式空气分选机

废钢尾料分选系统方案

SHREDDER RESIDUAL PRE-SORTING SOLUTION

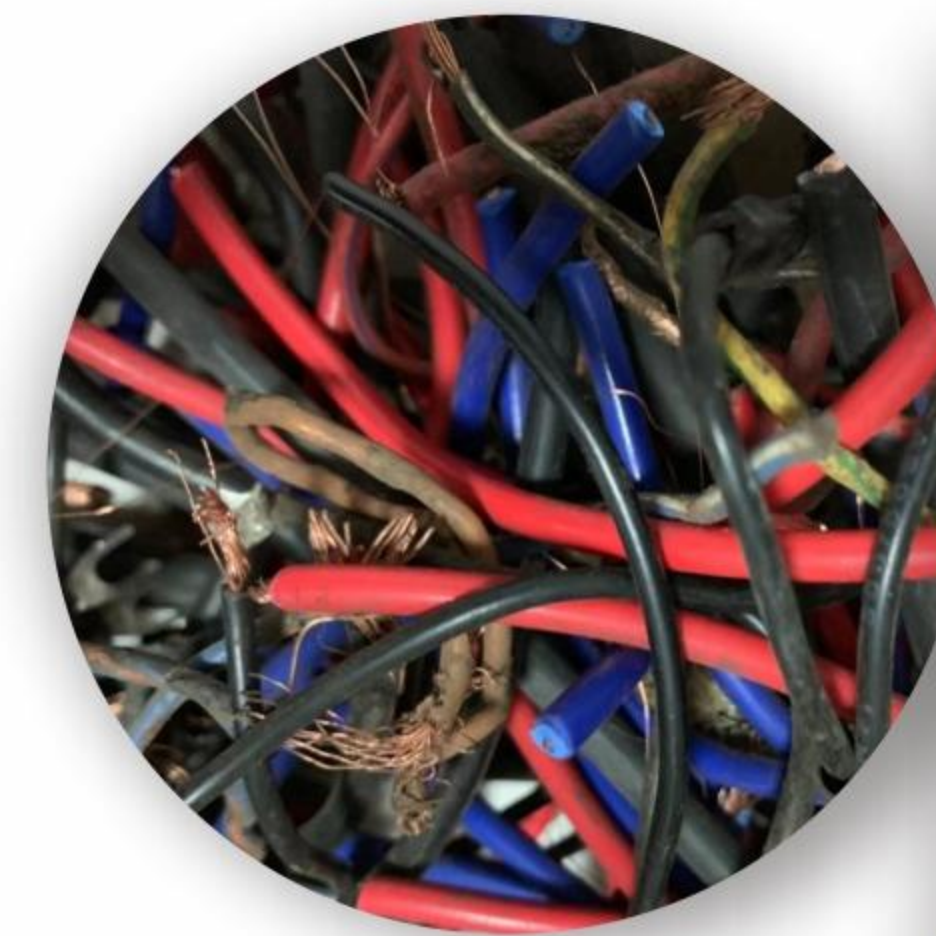
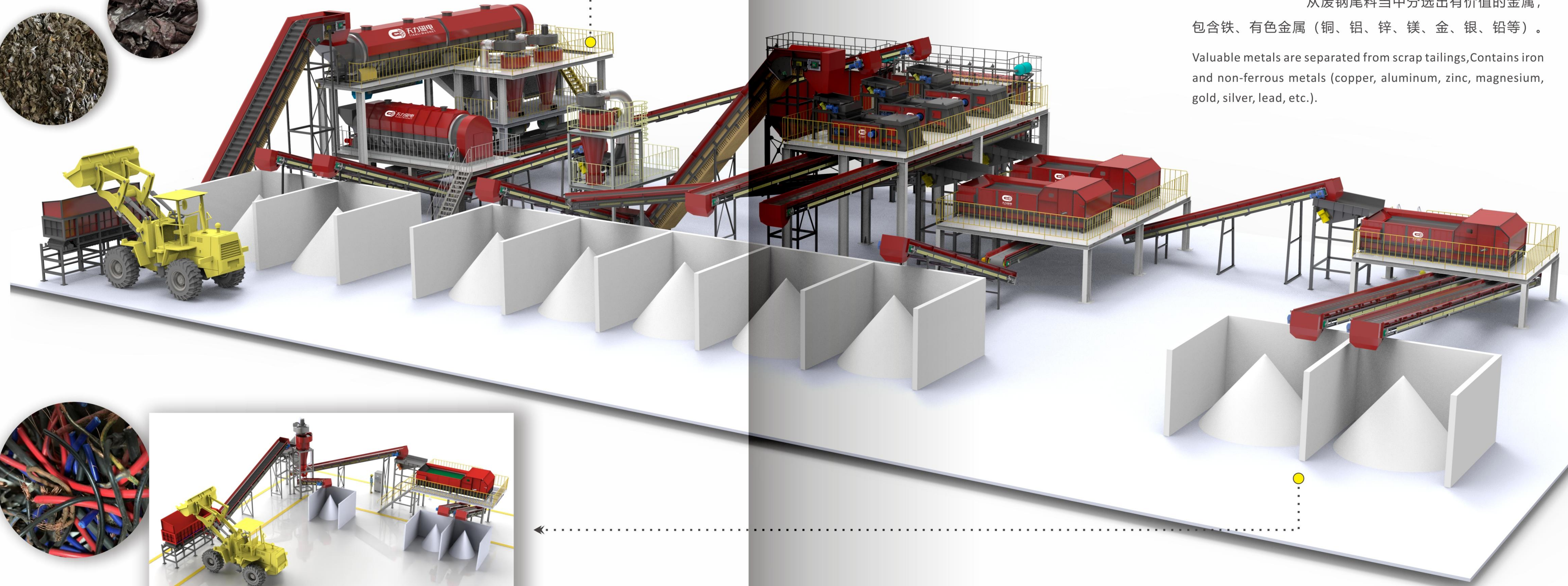

不锈钢分选系统方案



有色金属分选系统方案

方案目的

PROGRAM OBJECTIVES

从废钢尾料当中分选出有价值的金属，包含铁、有色金属（铜、铝、锌、镁、金、银、铅等）。
Valuable metals are separated from scrap tailings, Contains iron and non-ferrous metals (copper, aluminum, zinc, magnesium, gold, silver, lead, etc.).

**PRODUCT
ADVANTAGE**
产品优势

全进口轴承

采用全进口的轴承，有效保障设备运行的稳定的；

Imported bearings with long service life.

磁系终身不脱落

磁系采用独特的保护，有效保障磁系终身不脱落；

Special design prevent the magnetic system fall off.

源自世界磁都

磁材来自世界磁都，具有原产地的优势；

Magnetic materials come from the magnetic capital of the world and have the advantage of origin.

更全面的安全保障

安装了各种检查和报警系统，实时监控每个关键部件的操作；

Check and alarm system to monitoring machine operation.

采用喷塑处理工艺

整机采用喷塑处理，有效保证在特殊工况下的设备耐用性；

The machine adopts spray treatment to ensure the equipment durability under special working conditions.

特殊的磁系结果设计

采用特殊的磁系结构设计，提供更加高效的磁源，最大提升金属的感应抛力。

Special magnetic system structure is designed to provide a more efficient magnetic source to maximize the inductive throwing force of the metal.

本机采用偏心磁辊设计，大角度磁包角，配备振动给料机和挡板调节装置，紧凑合理的整机一体化设计，使得整机性能更稳定，分选效果更佳。

This equipment adopts eccentric magnetic rotor design, large Angle magnetic system, equipped with vibration feeder and baffle adjusting device, compact and reasonable integrated design of the whole machine, which makes the performance of the whole machine more stable and the separation effect better.

TLFXP 偏心涡电流分选机
**TLFXP ECCENTRIC
EDDY CURRENT SEPARATOR**



设备参数 Equipment Parameters

型号 Model	给料皮带 Feed Belt			处理能力 Capacity(m³/h)	耗能 Energy Consumption 总功率 Power(kw)	承重 Bearing 重量 Weight(kg)	外形尺寸 Overall Dimensions(mm)		
	给料宽度 Feed Width(mm)	给料长度 Feed Lengt	给料颗粒 Feed Size				长度 Length	宽度 Width	高度 Height
TLFX(P)-5	300	1500mm	≥1mm²	6	5.9	730	4600	1123	1200
TLFX(P)-6	400			10	5.9	895		1223	
TLFX(P)-6.5	400			15	5.9	950		1423	
TLFX(P)-8	600			20	5.9	1225		1623	
TLFX(P)-10	800			25	6.3	1555		1823	
TLFX(P)-12	1000			30	7.0	1875		2023	
TLFX(P)-14	1200			35	8.8	2275	2223		
TLFX(P)-16	1400			40	10	2850	2423		
TLFX(P)-17	1500			45	10	3150	2523		
TLFX(P)-20	1800			50	10.7	3650	2823		
TLFX(P)-22	2000			55	13	4500	3023		

使用领域 Field Of Use

主要适用于从工业废料、生活垃圾中分选出铜、铝等有色金属。

- 生活垃圾；
- 造纸厂尾渣；
- 废旧玻璃回收；
- 生活垃圾焚烧产生的炉渣；
- 废旧金属回收；
- 电子垃圾回收；
- 废旧塑料回收；
- 木屑。

It is mainly used for separating copper, aluminum and other non-ferrous metals from industrial wastes and household wastes.

- Household garbage.
- Tail residue of paper mill.
- Wood chips.
- Waste glass recycling.
- Scrap metal recycling.
- E-waste recycling.
- Recycling of waste plastics.
- Slag from household refuse incineration.

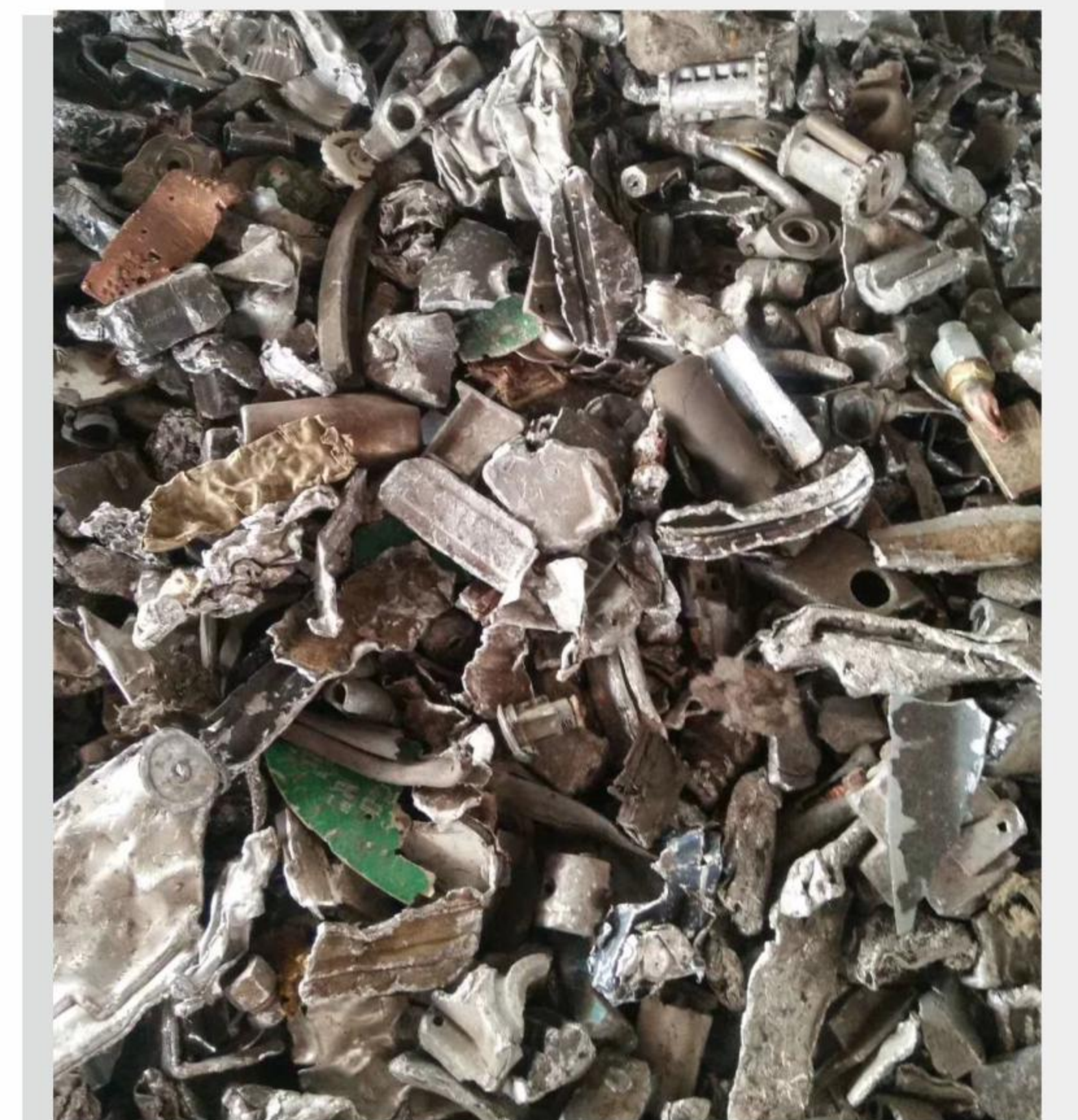

产品简介 Product Introduction

天力针对TLFX同心涡电流分选机提供两款机型：双辊同心涡电流分选机和三辊同心涡电流分选机；三辊同心涡电流分选机的设计相较于双辊同心涡电流分选机设计更合理，分选效果更优。

Tianli provides two models for TLFX concentric eddy current separator: Two-roll concentric eddy current separator and three-roll concentric eddy current separator. The design of three-roll concentric eddy current separator is more reasonable than two-roll concentric eddy current separator, with better separation effect.

TLFX 同心涡电流分选机

TLFX CONCENTRIC EDDY CURRENT SEPARATOR



设备参数 Equipment Parameters

型号 Model	给料皮带 Feed Belt			处理能力 Capacity(m³/h)	耗能 Energy Consumption 总功率 Power(kw)	承重 Bearing 重量 Weight(kg)	外形尺寸 Overall Dimensions(mm)		
	给料宽度 Feed Width(mm)	给料长度 Feed Length	给料颗粒 Feed Size				长度 Length	宽度 Width	高度 Height
TLFX-5	300	1500mm	≥25mm²	8	5.9	630	4600	1123	1200
TLFX-6	400			12	5.9	795		1223	
TLFX-6.5	400			15	5.9	850		1423	
TLFX-8	600			22	5.9	1120		1623	
TLFX-10	800			27	6.3	1450		1823	
TLFX-12	1000			32	7.0	1750		2023	
TLFX-14	1200			37	8.8	2150		2223	
TLFX-16	1400			42	10	2750		2423	
TLFX-17	1500			47	10	3000		2523	
TLFX-20	1800			52	10.7	3550	5000	2823	

产品简介 Product Introduction

物料通过振动给料机，均匀进入到Z型斗中，物料由于自由落体向下运动，在经过Z型斗的过程中，将物料充分打散，再经过离心风机将轻飘物和泥土向上吸进旋风除尘器中，通过旋风除尘器将轻物质和泥土排出，重的物质由于重力的作用，在Z型斗中直接掉下，进入到后续的分选工序。

Material by vibrating feeder, evenly into the bucket,Z material due to free fall downward movement, after the process of Z type hopper, will break the material thoroughly, repass centrifugal fan and the light and mud sucked up into the cyclone dust collector, through the cyclone speak light material and soil, heavy material due to the effect of gravity, in direct drop in the bucket , Z into the subsequent separation process.



TLZKF 立式空气分选机

TLZKF AIR SEPARATION

产品用途 Product Use

将废钢尾料中的轻飘物和泥土分离出来，从而得到干净的物料，提高分选效率和分选纯度。

The light material and soil in the waste steel tailings are separated to obtain the clean material and improve the separation efficiency and purity.

TLCG 电磁传感式分选机

TLCG METAL SORTER

天力TLCG电磁传感式分选机，采用高灵敏传感器技术识别/检测出废料中的金属颗粒，然后通过压缩空气喷嘴将金属颗粒从废料中分离开来，从而达到实现两种不同性质物料分离的目的。



TLCG Metal Sorter, based on high sensitivity sensor technology to identify/detect the metal particles in the waste material, and then the metal particles are separated from the waste material through the compressed air nozzle, so as to achieve the purpose of separating two materials with different properties.

产品规格 Product Parameters

阀组类型和喷嘴间距 Valve Type And Nozzle Spacing	TLCG-6	TLCG-12	TLCG-18	TLCG-24	TLCG-30
Ts1500/6.25mm	48阀门/valve	96阀门/valve	144阀门/valve	192阀门/valve	240阀门/valve
Ts400/6.25mm	96阀门/valve	192阀门/valve	288阀门/valve	384阀门/valve	480阀门/valve
TS200/6.25mm	96阀门/valve	192阀门/valve	288阀门/valve	384阀门/valve	480阀门/valve

传感器的典型应用 Typical Applications Of Sensors

典型应用/典型 Typical Applications		传感器类型 Sensor Type	
		A	B
各类金属回收 Metal Recycling	回收所有金属 Recycle All Kinds Of Metals	●	●
不锈钢 Stainless Steel	获得高纯度的不锈钢物料 Get High Purity Stainless Steel	●	●
线缆回收 Cable Recycling	获得高纯度的绝缘铜线物料 Recycle All Kinds Of Cables		●
塑料回收 Rubber Recycling	回收所有可见塑料 Recycle All Kinds Of Rubbers		●
塑料分选 Rubber Sorting	分选各种不同材料塑料，如PP/PS/PE,ABS/ABS-PC Sorted All Kinds Of Rubbers, Like PP/PS/PE, ABS/ABS-PC	●	●
特殊应用 Special Application	金属提纯和杂质剔除 Metal Impurity And Remove Contamination	●	●

PRODUCT ADVANTAGE

产品优势

- Annex process monitoring.
- Reduce compressed air consumption (15-25%).

- Improve product purity (5-15%).
- Maximize metal recycling.
- Stable separation performance.

- 提升产品纯度 (5-15%) ;
- 最大化金属回收;
- 稳定的分选性能;
- 附件过程监控;
- 减少压缩空气消耗 (15-25%) 。

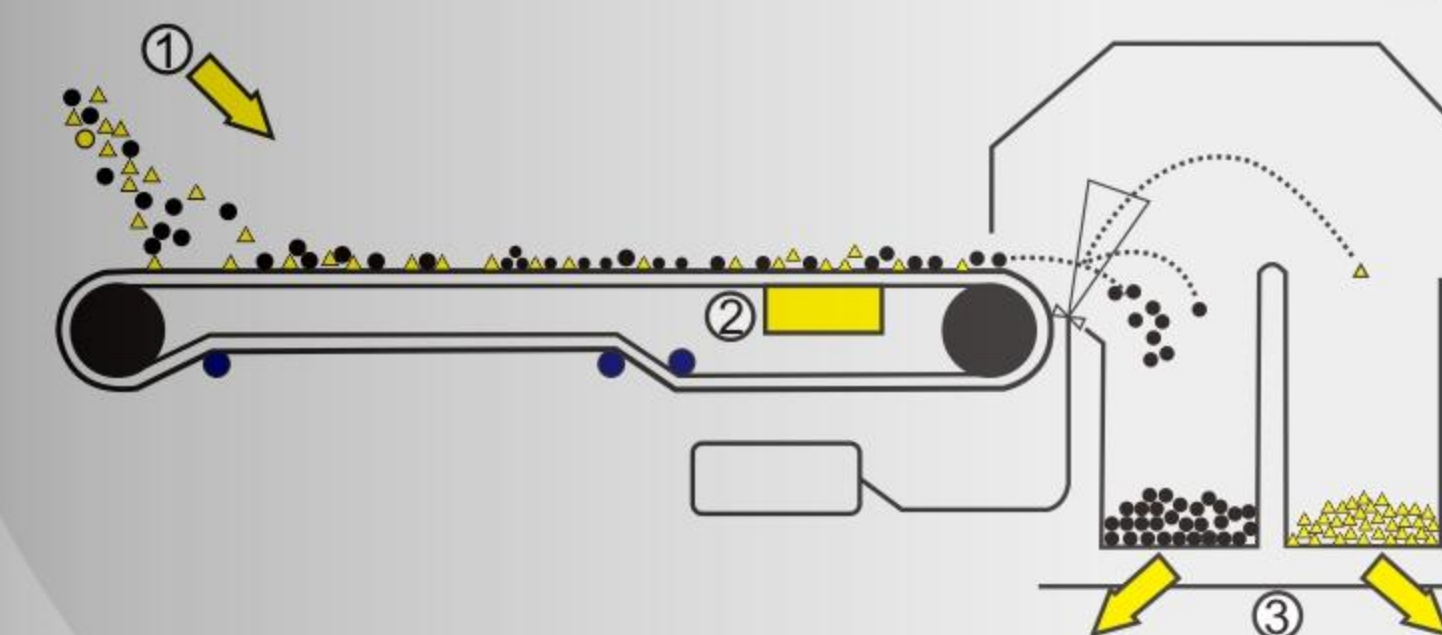

- ① 待分选物料输入/Feeding
- ② 电磁传感器/Sensor
- ③ 分离室/Separation Chamber

传感配置器 Sensor Configuration

- 采用集成特殊的图像处理技术的高灵敏电磁 (EM) 传感器，基于材料电导率进行识别，可实现在高产量下获得最高纯度。- Em3
High sensitivity electromagnetic (EM) sensor based on material conductivity identification is adopted with special integrated image processing technology to achieve the highest purity in high yield.-EM3
- 电磁 (EM) 传感器和近红外 (NIR) 光谱传感器的集成，可基于材料电导率及其独特光谱特征进行识别。- EM3-NIR1 ("poly")
The integration of the electromagnetic (EM) sensor and the near-infrared (NIR) spectrum sensor can be identified based on the material conductivity and its unique spectral features.-em3-nir1("poly")

备注：分辨率：两种可选的电磁传感器分辨率为卷径25mm和12.5mm，电磁传感器可探测的最小金属尺寸为1-2mm。

Remark:Resolution: the resolution of the two optional electromagnetic sensors is 25mm and 12.5mm,and the minimum metal size detected by the electromagnetic sensor is 1-2mm.

TLGTS 滚筒筛

TLGTS DRUM SCREEN

产品优点 Product Advantage

- 筛网采用耐磨材质，使用寿命更长；
- 有六角式和圆筒式双重选择，根据不同料型和筛分要求选择；
- The screen is made of wear-resistant material and has a longer service life.
- The screen can be customized according to the screening requirements.
- Adopt polyurethane driving mode, the equipment runs better and stably, with less noise.

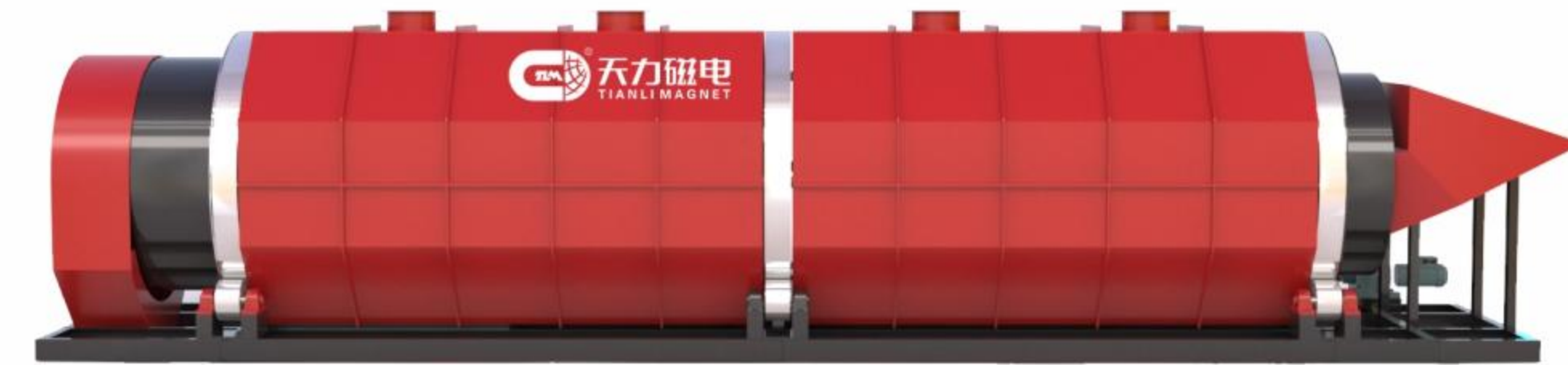

- 筛网可根据筛分要求，为客户量身定做；
- 采用聚氨酯驱动方式，设备运行更佳平稳，噪声小；
- 采用无轴式的设计，有效的针对比较复杂的垃圾物料。
- Adopt the no shaft design, effectively target the more complex garbage material.
- There are hexagonal type and cylinder type double choice, according to different material type and screening requirements.

TLCZ 弛张筛

TLCZ VIBRATORY SCREENS

广泛应用于极难筛分的潮湿物料，如废钢尾料、炉渣、建筑砂石等行业。

Widely used in extremely difficult to screen wet materials, such as asr material, slag, construction sand and stone industries.

产品简介 Product Introduction

主要用于极难筛分的物料，如：湿度大、片状、粘稠物料等容易堵塞筛孔的物料进行筛分，通过电机带动激振器的震动，使得柔性聚氨酯筛板产生“弛-张”的效果，促使这些极难筛分的物料获得一个极大的加速度而被从筛板上弹起，从而在保证高效筛分的同时，确保筛孔不被堵塞。

It is mainly used for screening of extremely hard materials, such as: high humidity, flake, sticky silk material such as easy to plug mesh material for screening, through the motor drive the vibration of the vibrator, make flexible polyurethane sieve plate "Vibrating" effects, prompting the screening of the extremely hard materials for a great acceleration and the bounce from the sieve plate, to ensure efficient screening at the same time, to ensure the mesh is not blocked.

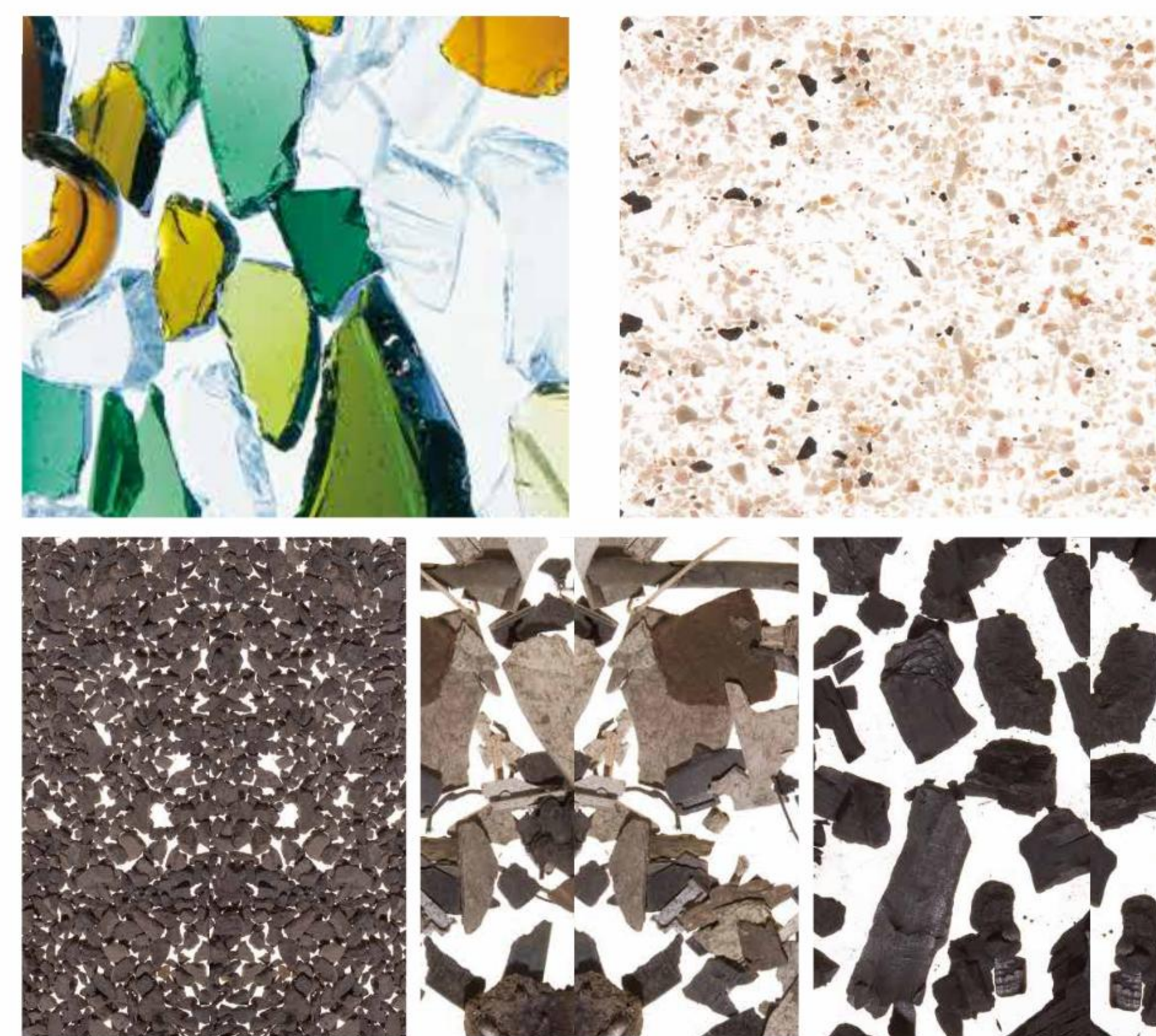

高效筛分散装物料
Efficient Screening Bulk Material

TLRL 燃料棒压块机

TLRL FUEL ROD BRIQUETTING MACHINE

产品优点 Product Advantage

- 采用高精度齿轮传动，传动效率高，工作稳定；
- 采用新型蛇型弹簧联轴器，补偿大，运转更平稳；
- 喂料器、调质器、斜槽采用不锈钢制作，经久耐用；
- 喂料器转速可调，能满足生产不同物料时的产量需求；
- 整机配有除铁和过载保护装置，充分考虑使用过程中对主机的保护；
- 整机传动系统关键部位采用进口轴承、油封，工作平稳、寿命长、噪音低。



- Material feeder, conditioning device, chute made of stainless steel, durable;
- The speed of the feeder can be adjusted to meet the output demand of different materials;
- The machine is equipped with iron removal and overload protection device, fully consider the use of the main engine protection;

- High precision gear transmission, high transmission efficiency, stable work;
- Adopt new type snake spring coupling, with large compensation and more stable operation;
- Imported bearing and oil seal are used in the key parts of the whole transmission system, with stable operation, long service life and low noise.

废钢尾渣塑料清洗回收线

PLASTIC CLEANING & RECYLING SOLUTION IN THE SCRAP STEEL INDUSTRY

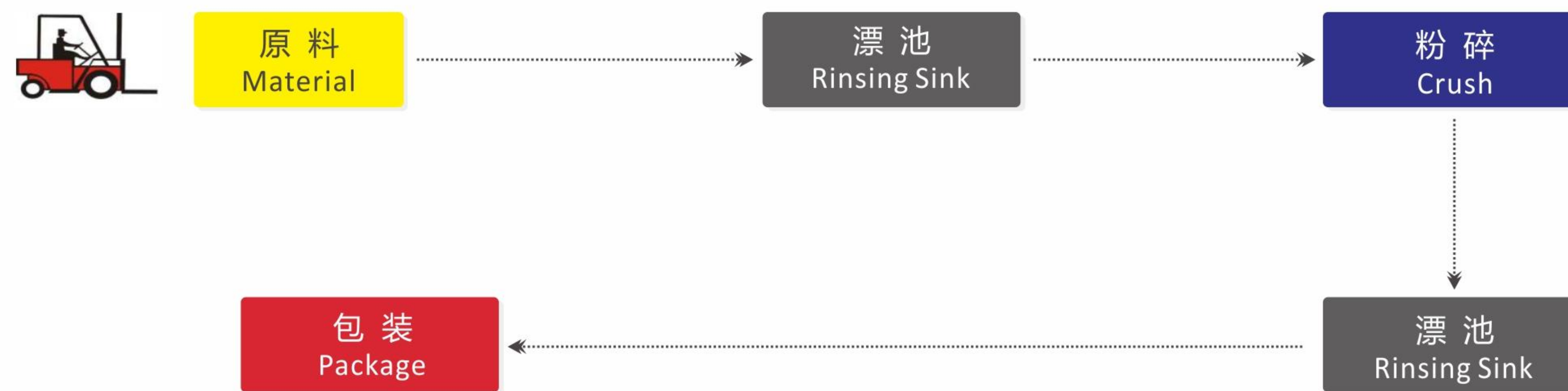

★ 天力可为您专业定制详细回收方案。 ★ Tianli can customize the recycling plan for you.

产品简介 Product Introduction

将物料破碎至所需尺寸，带水破碎。
带水破碎不仅能有效降低破碎时腔体内的温度，更能有效降低粉末料的产生。

Crushing materials to desired size with water. Water crushing can not only effectively reduce the temperature of the cavity during crushing.

More effective to reduce the production of powder.

粉碎机 SHREDDER



回收线简介 Sorting Line Introduction

天力磁电清洗回收线根据客户的实际需求和物料情况，结合多年的整线设计经验进行设计配置。根据客户的设计需求，将电杂料经过高速摩擦脱水、盐水分离、破碎、瓶片冷洗、脱水等工序后得到干净的物料。

Tianli magnet cleaning and recycling line is designed and configured according to customer's actual demand and material situation, combined with years of whole line design experience. According to the design requirements of customers, electric miscellaneous materials are obtained after high-speed friction dehydration, brine separation, crushing, cold washing and dehydration of bottle slices and other processes.

分离槽 (盐水/清水) PRE-WASHING MACHINES

产品简介 Product Introduction

清水清洗物料，分离出浮料-PP料，并且去除物料中残留的轻质杂料，如泡沫。

根据密度法盐水分离出沉料，如金属、橡胶/玻纤等。

Clean the material with water, separate the floating material-PP, and remove the remaining light miscellaneous material in the material, such as foam.

According to the density of brine separation of sediment, such as metal, rubber/glass fiber, etc.

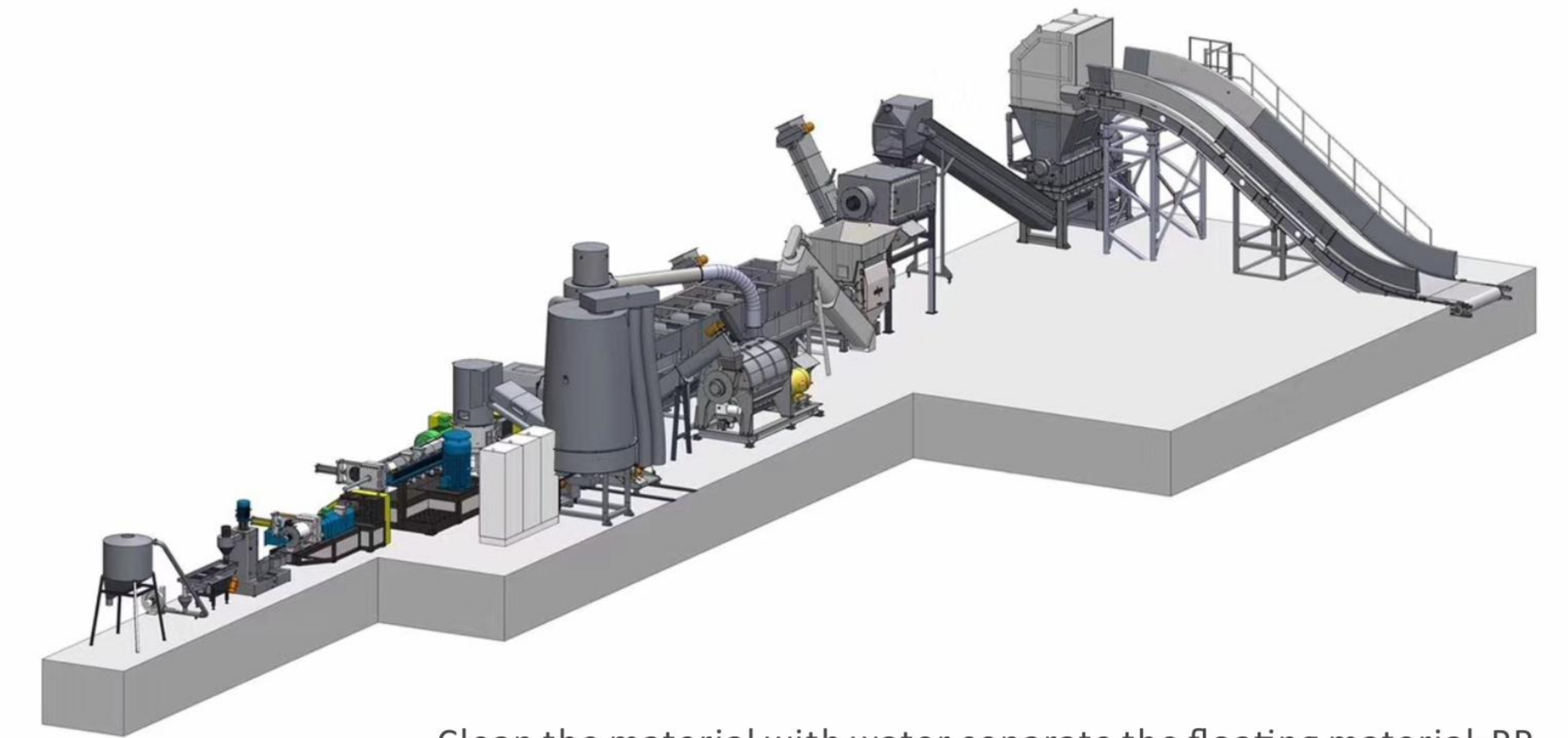

TLRCT 上部进料磁滚筒

TLRCT Upper Feed Magnetic Drum

产品简介 Product Introduction

本产品是经振动给料机从磁选滚筒上部进料的一种半磁封闭式结构磁选设备。磁场强度1000-8000Gs可选，吸铁能力大，分选效果好。

This product is a kind of Semi-magnetic closed-type structure magnetic separator, which is fed by vibrating feeder from the upper part of magnetic drum. The magnetic field strength of 1000-8000Gs can be selected.

产品优点 Product Advantage

- 滚筒采用有效的防护装置，防止筒皮磨损；
- 磁场强度高、磁场的范围大、磁滚筒表面从1000-8000GS根据客户实际情况选定；
- 自动分离、连续作业、处理量大、回收率高；
- 结构简单、运行可靠、易于安装。

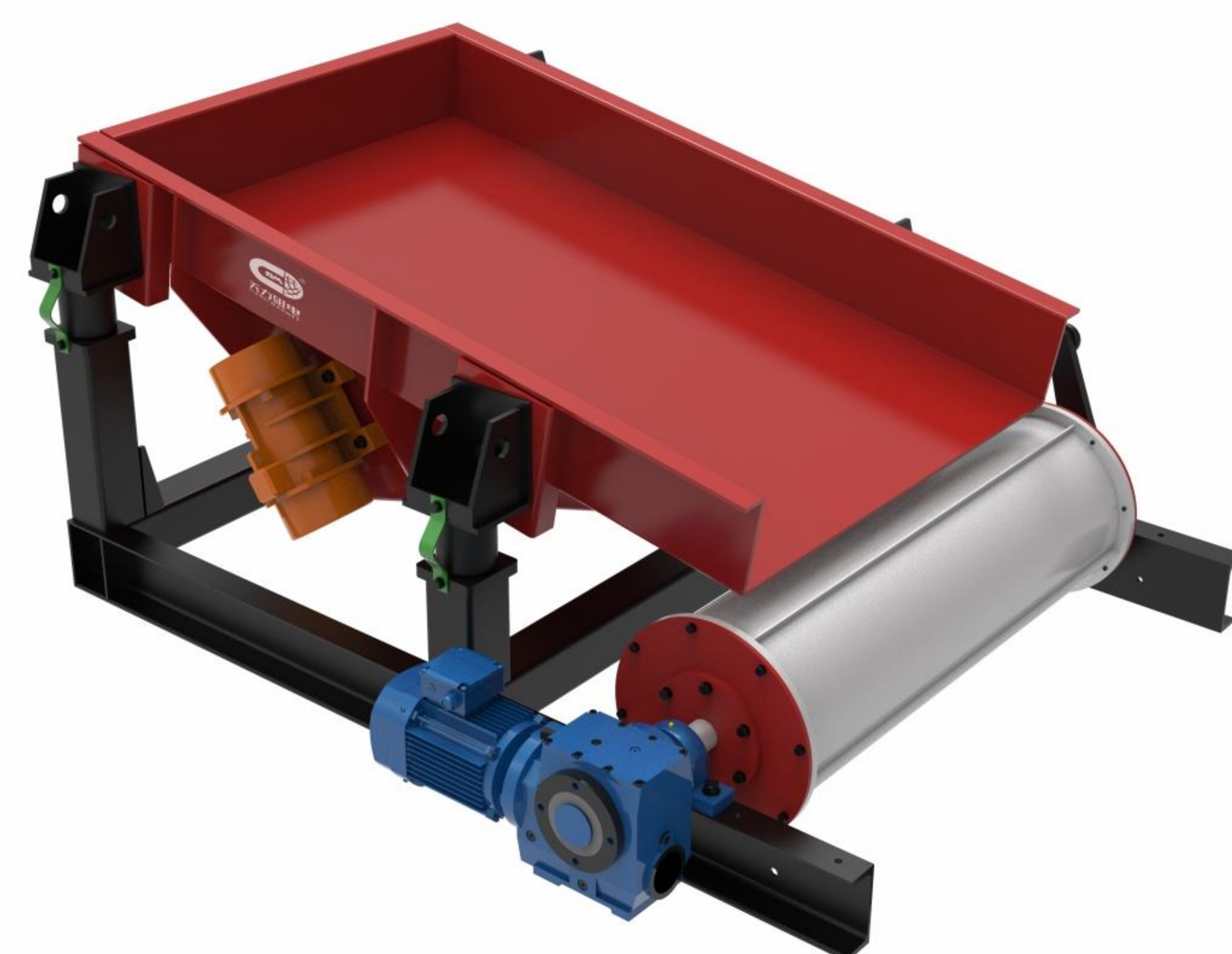

- Drum adopt effective protective device, to prevent the cylinder wear.
- Strong magnetic field intensity, the range of magnetic field is big, magnetic drum mixer surface from 1000-8000gs selected according to the customer.
- Automatic separation, continuous operation, large capacity, high recovery rate.
- Pieces of simple structure, reliable operation, easy to install.

TLSXG 永磁上吸式磁滚筒

TLSXG Perm-Magnetic Drum

产品简介 Product Introduction

- 电磁式和永磁型；
- 用于加工各类有色金属；
- 自动地分离铁磁性物质；
- 适用于废钢，含铁量大和有尖锐铁件的物料。

- Electromagnetic type and perm-magnet type;
- For processing from many nonferrous metals;
- Automatic continuous separation of ferromagnetic substance;
- Suitable for steel scrap, separation for large amount of iron and iron sharp materials.

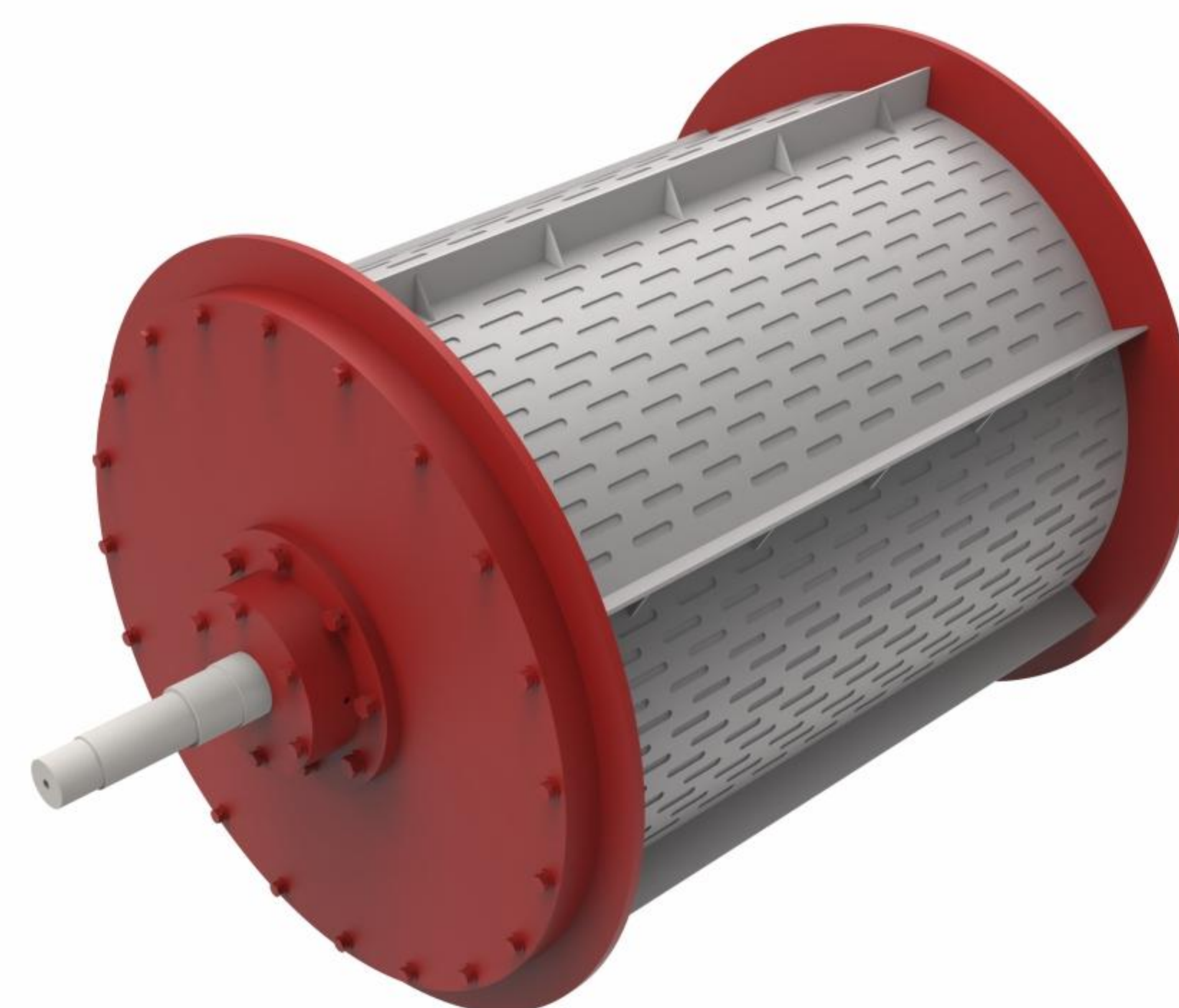

RCDD 电磁自冷自卸式除铁器

RCDD Self-Cleaning Electromagnetic Separator

- 磁路采用计算机模拟设计，透磁深度大，磁力强；
- 自动卸铁、维护简便、滚筒腰鼓形结构，具备皮带自动纠偏功能，可实现长期无故障运行；
- 产品配套性好，整流设备功能齐全，具有手动和集控功能，能满足多种场合的使用要求；
- 自冷式全密封结构，防尘、防雨、防盐雾、耐腐蚀；
- 可有效吸除混杂在非磁性物料中0.1-30公斤的铁磁性物质。
- Self-cooled full-sealed structure, anti-dust, anti-rain, corrosion resistance.
- Adopting the computer simulation to design the Magnetic circuit, with deeper penetration, higher magnetic force.
- Automatic unloading iron, easy maintenance, The drum with waist drum structure, and automatic belt correction function, can achieve long-term trouble-free operation.
- Product matching is good, rectifier equipment is complete, with manual and centralized control function, to meet the requirements of a variety of occasions.
- Can effectively remove the ferromagnetic material weighed between 0.1-30kg mixed in the non-magnetic materials.



RCYD 自卸式永磁除铁器

RCYD Self-Cleaning Perm-Magnetic Separator

- 磁路采用计算机模拟设计，完善的双磁极结构，磁场强度高，梯度大，吸力大；
- 高性能钕铁硼做磁源，磁能积高，不易退磁，八年退磁不超过5%；
- 腰鼓形滚筒结构，具备自动纠偏功能，全密封轴承座，密封性好，能适应各种恶劣环境；
- 皮带自动卸铁，可保障长期无故障连续运行。
- Adopting the computer simulation to design the Magnetic circuit, with perfect double magnetic pole structure, higher magnetic intensity, higher gradient, higher magnetic force.
- High-performance NdFeB magnetic material as the magnetic source, High magnetic energy, not easy to demagnetize, and demagnetization does not exceed 5% in 8 years.
- Waist drum-shaped drum structure, with automatic correction function, fully sealed bearing, good sealing, can adapt to a variety of harsh environments.
- Automatic unloading belt, can guarantee long-term trouble-free continuous operation.

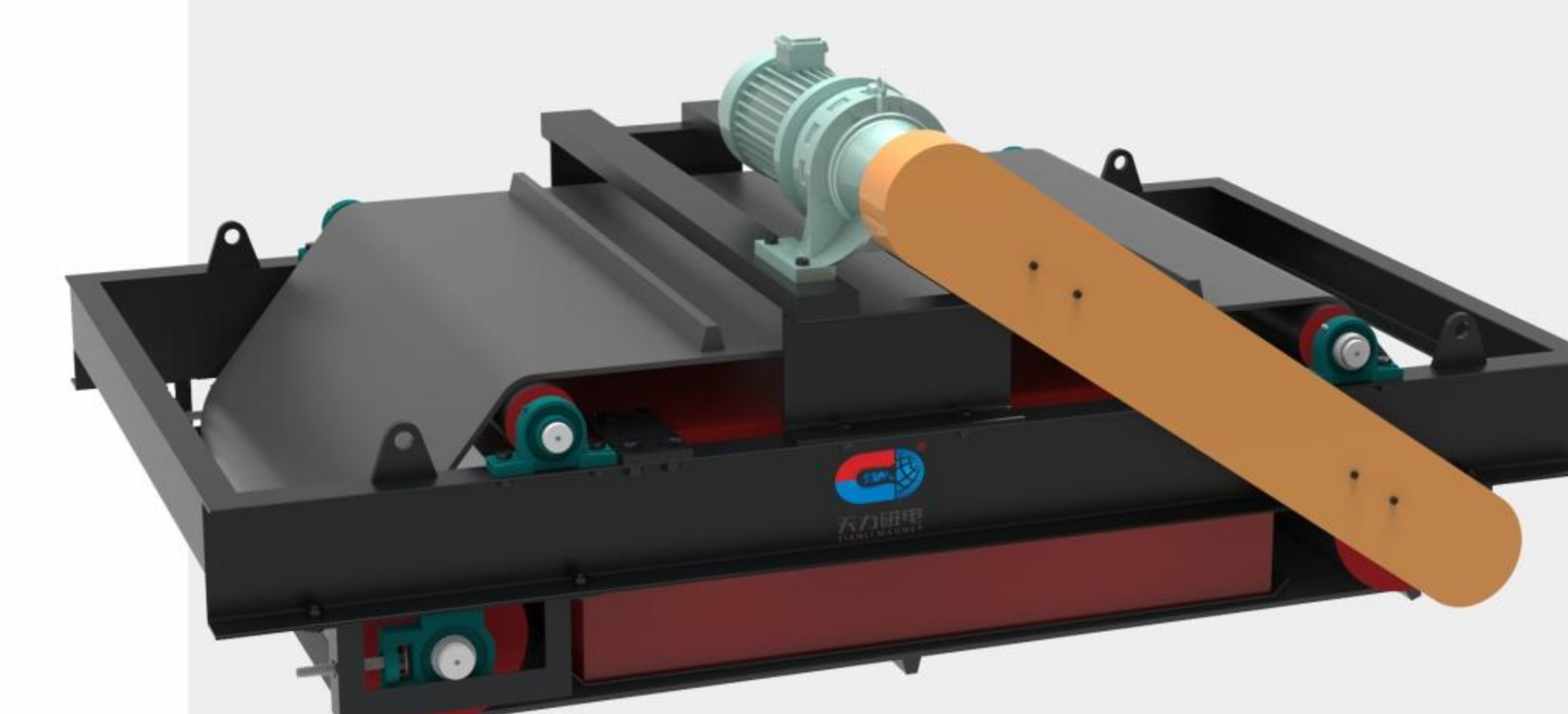

TLBL 板链式给料机

TLBL Board Chain Feeder

产品简介 Product Introduction

适用于从储料仓到破碎机、振动筛、配料等机械设备的短距离输送。进料均匀，无需人工操作，自带拨料功能，板链式给料机对物料有较大的适应性，不受物料的粒度、比重大小限制。

Suitable for short distance transportation from storage bin to crusher, shaker, batching and other mechanical equipment. Uniform feeding, no manual operation, with its own pulling function, board chain feeder has greater adaptability to the material, not limited by the size of the material, specific gravity.



大倾角皮带输送机

Large Inclination Belt Conveyor

产品简介 Product Introduction

大倾角皮带输送机可以大角度输送，具有输送量大，占地面积小，维护简单等特点，广泛被使用。

Large Angle belt conveyor can be large Angle transmission, with a large amount of conveyor, small area, simple maintenance and other characteristics, widely used.



TLBL 板链式输送机

TLBL CHAIN CONVEYOR

产品简介 Product Introduction

板链给料机是关键输送设备，具有物料接受及暂存功能，能根据后续处理设备能力调整输送量和输送时间。

适用范围广；扭矩大，高效节能；噪音小，耐久性强。

Chain Conveyor is the key conveying equipment, with material acceptance and temporary storage function. It can adjust the conveying volume and conveying time according to the capacity of subsequent processing equipment.

Wide range of application; high torque, high efficiency and energy saving; low noise, high durability.

电气控制系统(整线)

Electric Control System (Whole Line)

电气控制系统采用PLC编程控制系统，可以自动控制、设置超载自动反转控制功能。

The electrical control system adopts PLC programming control system, which can automatically control and set the overload automatic reverse control function.

我公司承接废钢行业重型链板输送机、辊筒式输送机、旋转式输送机、皮带输送机等各种输送设备和国内外各种上式电磁滚筒、永磁滚筒、磁选机的生产维修业务，欢迎大家咨询采购！

Our company undertakes heavy-duty chain conveyor, roller conveyor, rotary conveyors, belt conveyors and other conveying equipment and domestic and foreign Various kinds of upper type electromagnetic roller, permanent magnetic roller, magnetic separator production and maintenance business.

We welcome your inquiry and purchase!

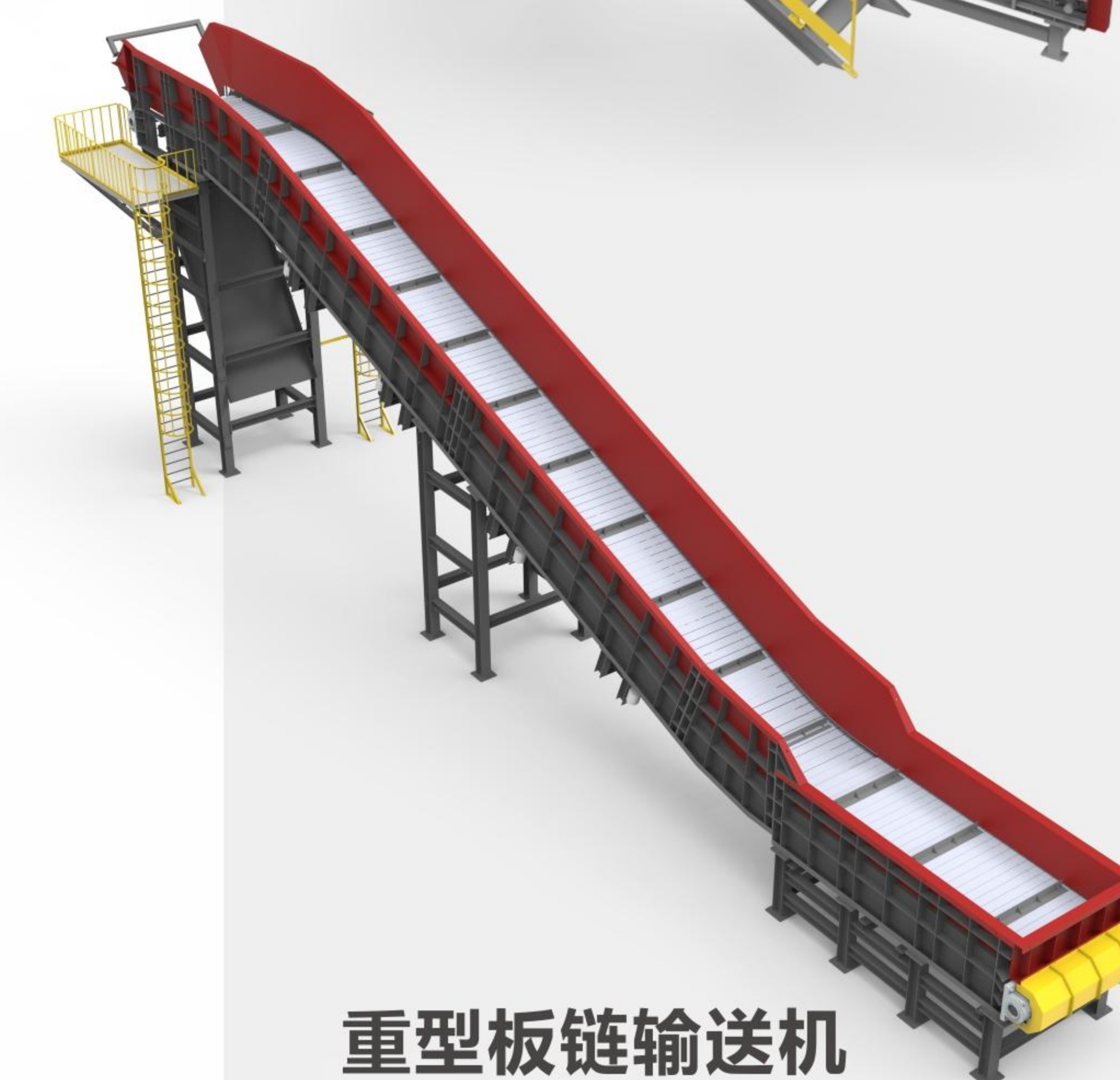
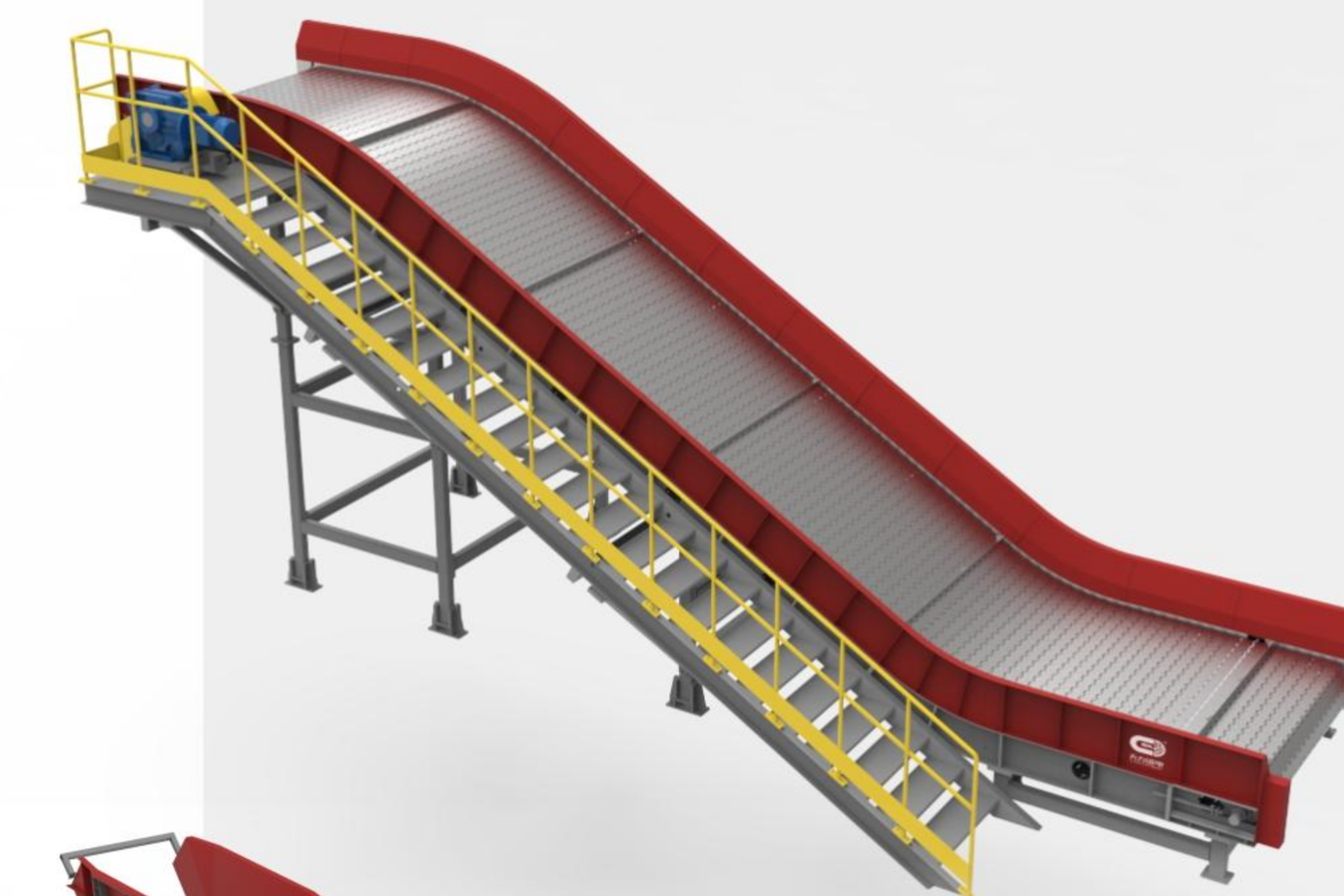

重型板链输送机
HEAVY DUTY CHAIN CONVEYOR

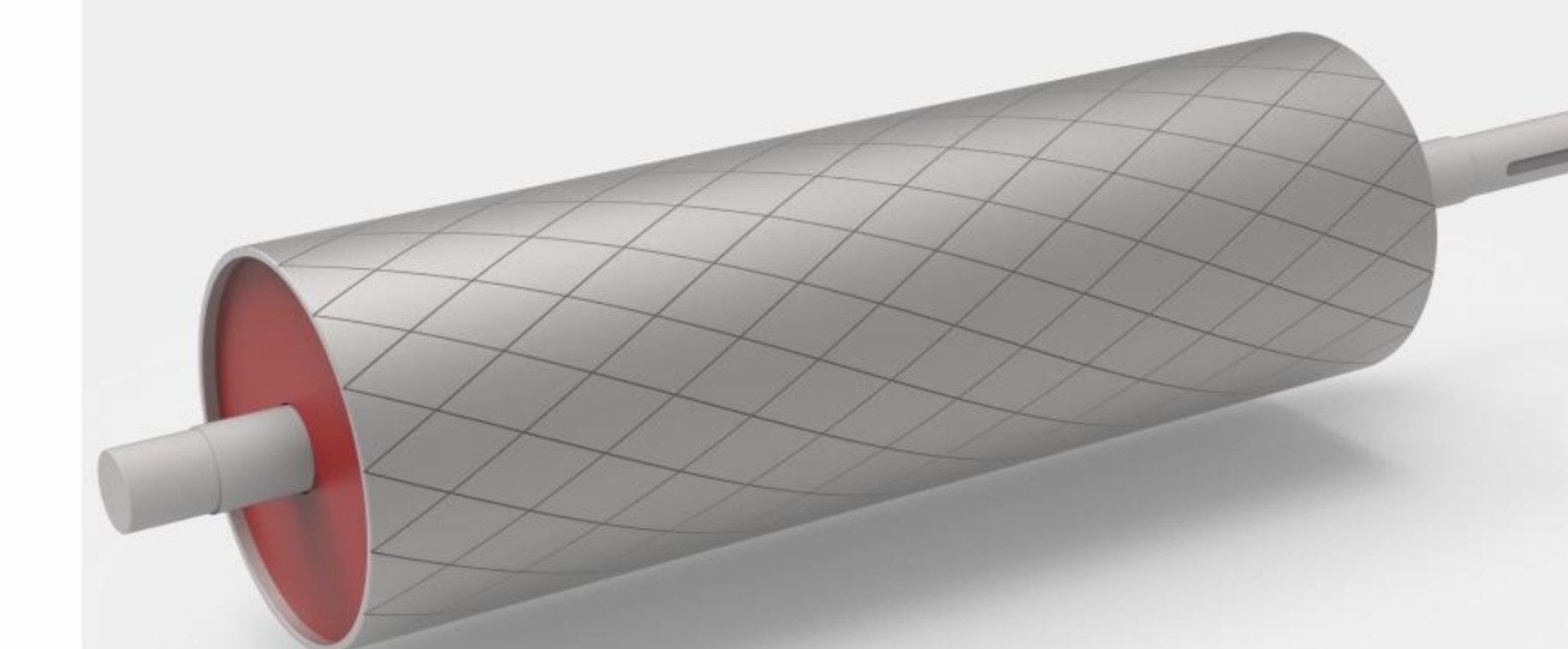

全磁滚筒
Full Magnetic Roller



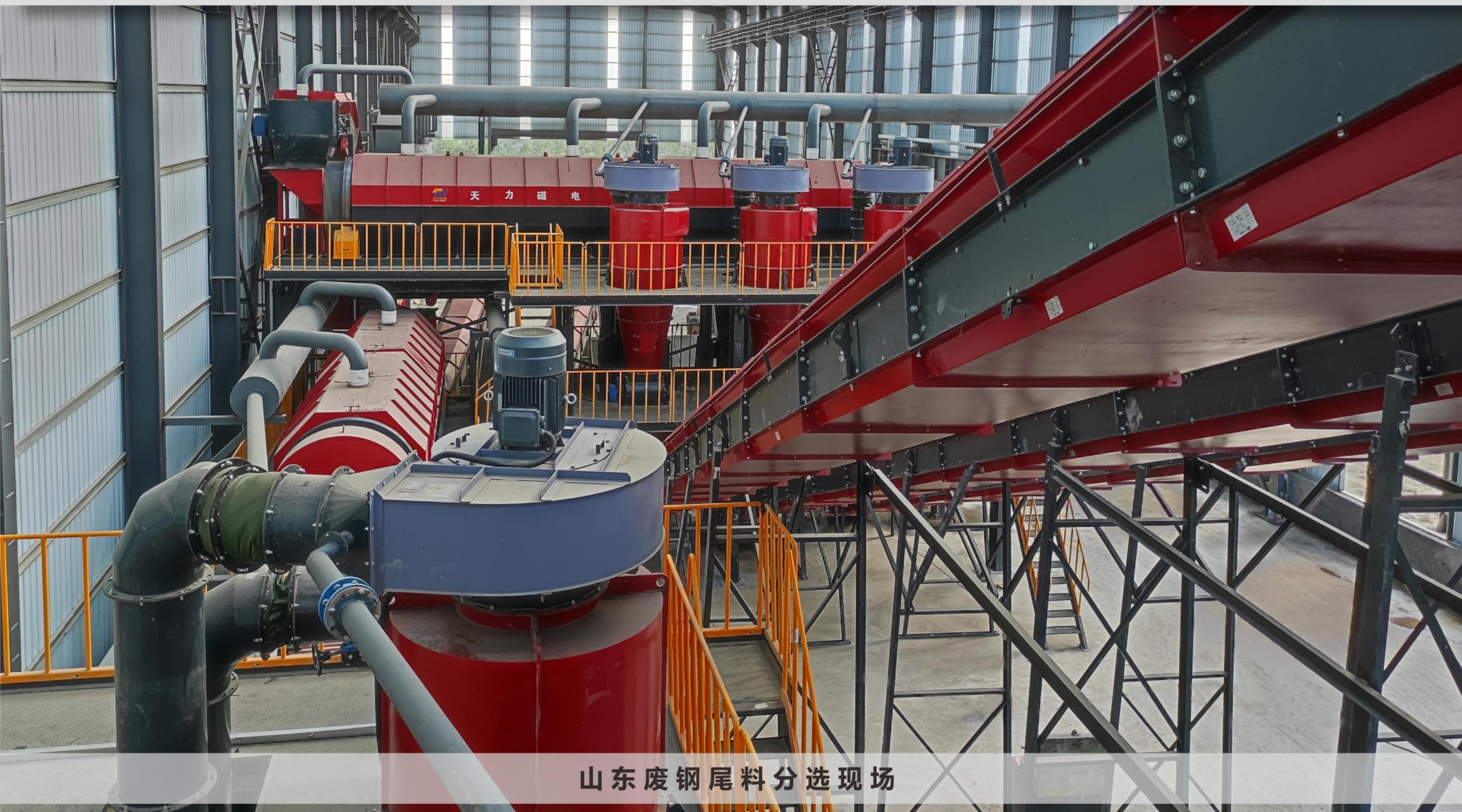

山东废钢尾料分选现场



广州废钢尾料分选现场



江苏废钢尾料分选现场





除铁器应用于废钢破碎线现场



上吸式磁滚筒应用于废钢破碎线现场



国外废钢尾料分选现场





除铁器应用于废钢破碎线现场



除铁器应用于废钢破碎线现场



及时提供合同相关设备的安装调试，全面配合验收。

Timely provide the installation and debugging of contract related equipment, and fully cooperate with the acceptance.



实施“一对一营销”，全面建立客户档案，服务结果请客户签字确认后存档。

Implement "one-to-one marketing" and build up comprehensively Customer files, service results please sign for confirmation after archiving.



随时解决顾客反馈的问题，有关产品质量投诉保证派出最佳人员赴现场。

Solve customer feedback problems at any time, and guarantee to send the best personnel to the site for product quality complaints.



固废整体解决方案提供商！

全国统一服务电话

400-1122-958

感谢您对天力磁电的信任与厚爱

THANK YOU FOR YOUR TRUST AND LOVE
TO TIANLI MAGNET